



MASON INDUSTRIES, Inc.

MERCER RUBBER Co.

350 Rabro Drive, Hauppauge, NY 11788
 Mason- 631/348-0282 • Info@Mason-Ind.com
 Mercer- 631/582-1524 • Info@Mercer-Rubber.com
 FAX 631/348-0279



JOB NAME _____
 CUSTOMER _____
 CUSTOMER P.O. _____
 MASON M. _____
 DWG No. _____

EJFFL250

**BELLOWS
 EXPANSION
 JOINT with FIXED
 and FLOATING
 FLANGES**

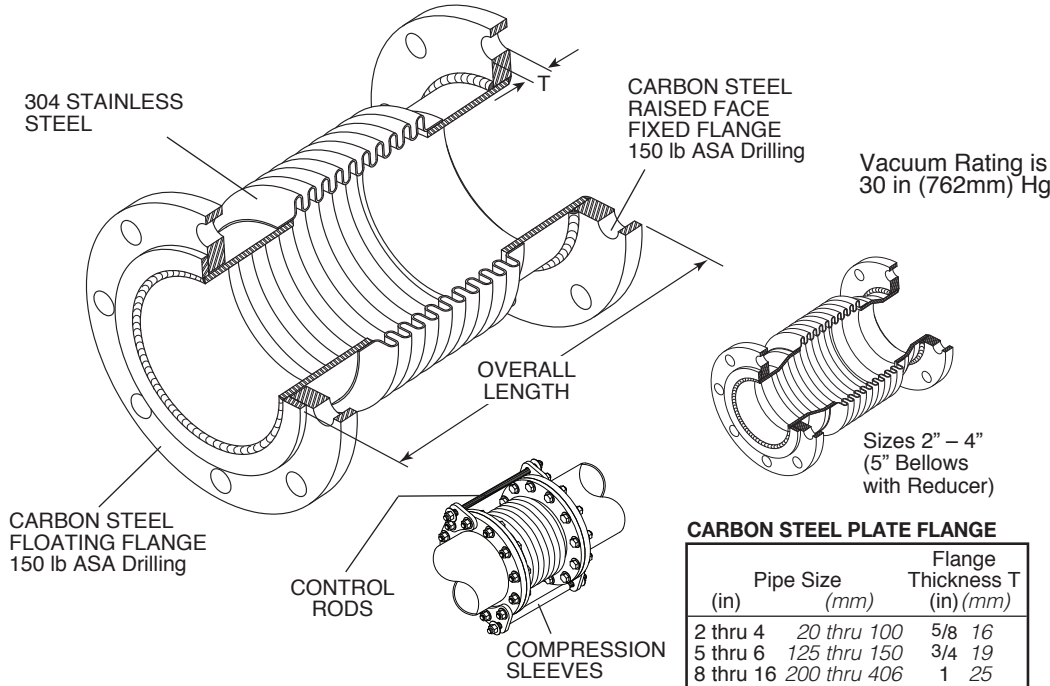

PRESSURE REDUCTION TABLE

Temperature (°F)	Temperature (°C)	Rated Pressure (psi)	Rated Pressure (kg/cm²)
200	93	188	13.2
250	121	184	12.9
300	149	176	12.3
400	204	166	11.6
500	260	156	10.9
600	316	148	10.4
700	371	140	9.8
800	427	Not Recommended	

FLANGE BOLT and NUT REQUIREMENT (by Others)

EJFFL250 Size	Quantity	Size & Length
2 & 2 1/2	8	5/8 x 3
3	8	5/8 x 3 1/4
4	16	5/8 x 3 1/4
5 & 6	16	3/4 x 3 1/2
8	16	3/4 x 4
10 & 12	24	7/8 x 4 1/4
14 & 16	24	1 x 4 1/2

EJFFL250 DIMENSIONS AND PRESSURE RATINGS 2" (50mm) AXIAL MOVEMENT, 1/4" (6mm) LATERAL DEFLECTION

Type & Size	Pipe Size		Overall Length		Axial Spring Rate		Lateral Spring Rate		Thrust [†] @		Rated Pressure @70°F @21°C		Ship Wt.	
	(in)	(mm)	(in)	(mm)	(lbs/in)	(kg/cm)	(lbs/in)	(kg/cm)	250 psi (lbs)	17 kg/cm² (kg)	(psi)	(kg/cm²)	(lbs)	(kg)
EJFFL250-2	2	51	21	533	1522	272	2041	365	7069	3206	250	17	15	7
EJFFL250-2 1/2	2 1/2	64	21	533	1522	272	2041	365	7069	3206	250	17	15	7
EJFFL250-3	3	76	21	533	1522	272	2041	365	7069	3206	250	17	15	7
EJFFL250-4	4	100	21	533	1522	272	2041	365	7069	3206	250	17	15	7
EJFFL250-5	5	125	14 1/4	362	1522	272	2041	365	7069	3206	250	17	16	8
EJFFL250-6	6	150	16 1/2	419	1961	350	2451	438	9621	4364	250	17	22	10
EJFFL250-8	8	200	17 1/4	438	2041	364	3979	711	15905	7214	250	17	38	17
EJFFL250-10	10	250	18	457	2502	447	7786	1390	23758	10776	250	17	52	24
EJFFL250-12	12	305	19	483	1693	302	17419	3111	33183	15052	250	17	70	32
EJFFL250-14	14	356	20	508	3705	662	17568	3137	44179	20039	250	17	92	42
EJFFL250-16	16	406	20 1/2	521	4663	833	30655	5474	56745	35739	250	17	112	51

[†]Lower Thrust Forces in proportion at lower pressures, i.e. 100 psi Force = 100/225 x published Thrust. Forces on Pipe Anchors must include Thrust Force and Spring Force. Spring Force is determined by multiplying the joint Spring Rate by its Thermal Movement. (in/mm)

EJ's installed in piping systems must be anchored on both sides of the joint. EJ's installed in unanchored piping must have control rods.

When using EJFFL products in copper or brass water or steam systems, dielectric flanges must be used on each end to prevent leakage from galvanic action.

GUIDE SPACING – Referencing Pipe Diameter "D"

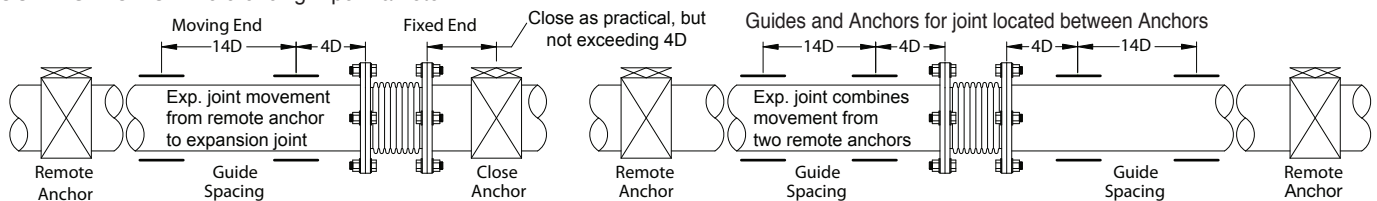

*Plus an additional 5" (125mm) for Sizes 2 & 2 1/2

QTY	SIZE	TAG

QTY	SIZE	TAG